

Narrow Block Type SL

Long narrow block. Available in different accuracy classes and preload options.

Very high load capacity, stiffness and precision.

Dimensions in mm. (According to the DIN 645/I standards.)

Lead time/availability in the table below are only indications. Choice of preload and accuracy class will affect lead time. Please contact us for exact delivery time for your request.

Higher accelerations and speeds than listed below are possible according to preload, load, lubrication and assembly position values. In these cases, please contact us for advice.

Max. Operating Speed (m/s): 3

Max. Acceleration (m/s²): 50

Temperature range (°C): -10 °C to +80

Material: Hardened alloy steel blocks with rollers of hardened bearing steel. Plastic parts.



General Data



Designation	Dynamic Load Capacity C (N)	Static Load Capacity C0 (N)	Static Moment Mr0 (Nm)	Static Moment Mp0 (Nm)	Static Moment My0 (Nm)
RMG25SL	38900	76800	1150	970	970
RMG35SL	72600	136000	3014	2243	2243
RMG45SL	119500	242200	6672	4951	4951
RMG55SL	176000	351000	11915	8910	8910
RMG65SL	276000	579000	22100	11840	11840

Designation	Dynamic Moment Mr (Nm)	Dynamic Moment Mp (Nm)	Dynamic Moment My (Nm)
RMG25SL	583	491	491
RMG35SL	1595	1187	1187
RMG45SL	3293	2444	2444
RMG55SL	5977	4470	4470
RMG65SL	10530	8980	8980

Dimensions

Block type SL

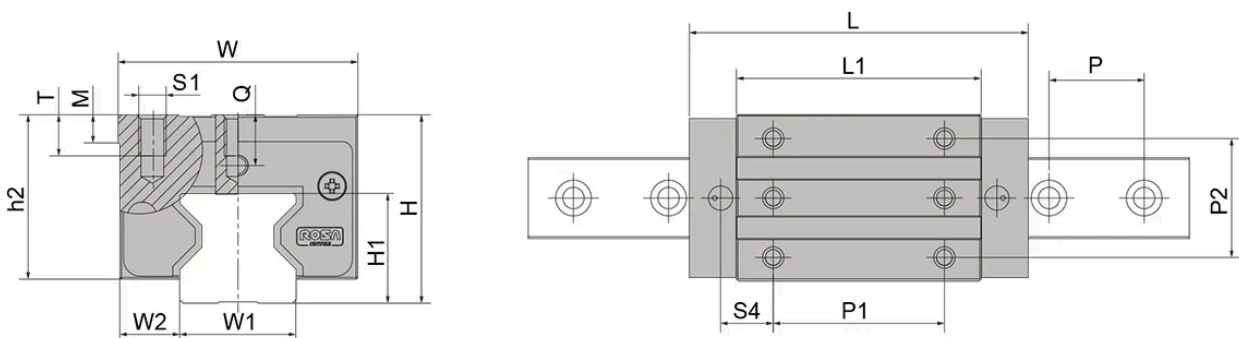

Designation	L	H	W	L1	H1	h2	W1	W2	S1
RMG25SL	109.7	40	48	81.5	24.5	33.5	23	12.5	M6

Designation	L	H	W	L1	H1	h2	W1	W2	S1
RMG35SL	142.3	55	70	103	32	48	34	18	M8
RMG45SL	179.8	70	86	133.8	40	60	45	20.5	M10
RMG55SL	215	80	100	162	48	67	53	23.5	M12
RMG65SL	272.3	90	126	210.3	55	78	63	31.5	M16

Designation	S4	Q	T	Hole Pitch (P)	P1	P2	M
RMG25SL	21.2	9.5	9	30	50	35	7.5
RMG35SL	22	14.9	12	40	72	50	8
RMG45SL	33.9	18	18	52.5	80	60	10
RMG55SL	42.5	19.8	19	60	95	75	12
RMG65SL	57	15	22	75	120	76	15.5