

PSAS ---.6200

- Polyamide roller combined – fixed axial roller with higher load capacity
- Lubricated for lifetime
- High abrasion resistance
- Low friction
- High chemical resistance to alcohol, salts, greases and certain acids and alkalis in diluted concentration.

Reduction of value by speed of:

1 m/sec: 0%

2 m/sec: -20%

3 m/sec: -30%

Use profile UP---.0730

Order example: Roller + fixing plate PAS040.0360/BQ1000
Roller Ø 40 mm - welded with mounting element 50 mm x
50 mm x 8 mm

Dimensions in mm.

Temperature: Maximum working temperature 80° C

Speed: Travel speed up to 5 m/sec

Roller Type: Polyamide

Sizes Available: 60; 100; 125; 145; 160; 180





General Data

FA = System Load Capacity Axial
 FR = System Load Capacity Radial
 Ca = Dynamic Load Capacity Axial
 C = Dynamic Load Capacity Radial

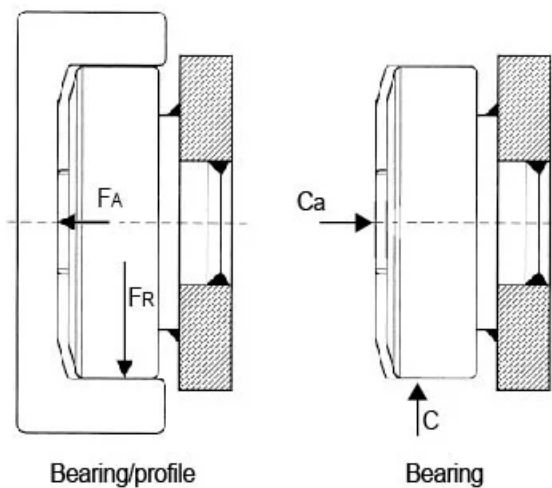

Designation	System Load Capacity Radial (N)	System Load Capacity Axial (N)	Profile
PSAS060.6200	1500	900	UP---.0730
PSAS100.6200	2500	1800	UP---.0730
PSAS125.6200	6000	2500	UP---.0730
PSAS145.6200	8000	5000	UP---.0730
PSAS160.6200	10000	5000	UP---.0730
PSAS180.6200	15000	6500	UP---.0730

Dimensions

PSAS 060.6200 & PSAS 100.6200

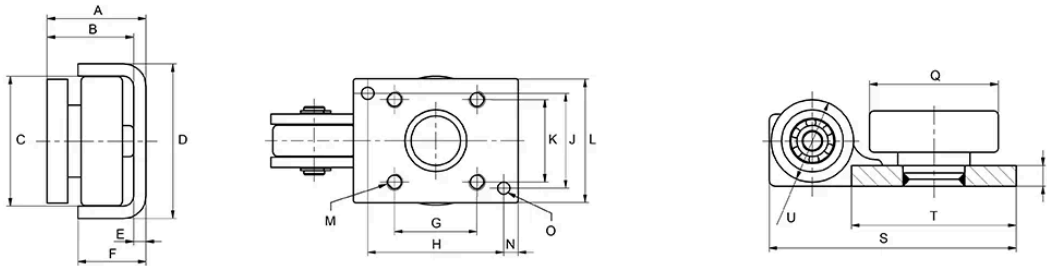

PSAS 125.6200 & PSAS 145.6200
PSAS 160.6200 & PSAS 180.6200

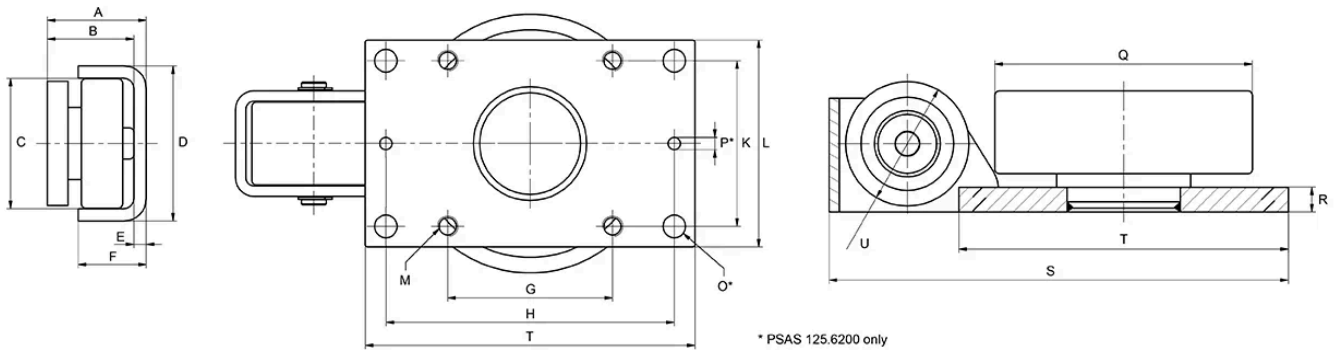

Designation	A	B	C	D	E	F	G	H	J
PSAS060.6200	48	42	63	75	6	33	40	66	46
PSAS100.6200	57	51	102	114	6	40	80	105	80
PSAS125.6200	71	63	126	142	8	56	80	140	—
PSAS145.6200	96	88	146	162	8	65	130	—	—
PSAS160.6200	96	88	159	175	8	73	140	—	—
PSAS180.6200	98	88	180	200	10	70	160	—	—

Designation	K	L	M	N	O	P	Q	R	S	T
PSAS060.6200	40	60	4 x M8	7	2 x Ø6	—	62.5	10	120	80
PSAS100.6200	80	100	4 x M10	7.5	2 x Ø6	—	101.2	10	160	120
PSAS125.6200	80	100	4 x M10	—	4 x Ø11	2 x Ø6	125	12	223	160
PSAS145.6200	90	120	4 x M16	—	—	—	145	20	263	180
PSAS160.6200	90	120	4 x M16	—	—	—	158	20	273	190
PSAS180.6200	90	120	4 x M16	—	—	—	179	20	295	210

Designation	U
PSAS060.6200	40
PSAS100.6200	40
PSAS125.6200	60
PSAS145.6200	80

Designation	U
PSAS160.6200	80
PSAS180.6200	80