

Linear Unit QME-WIL – Right+Left Drive

With handwheel locking and position indicator.

QME with right + left drive is a ready to mount positioning table guided with linear ball bearings on hardened shafts and driven by ball-or lead screw. QME can be manually driven by handwheel using either ball screw or lead screw. For drive by motor, the ball screw versions are strongly recommended for sustained performance and precision.

Rollco recommend locking device for all hand driven units with ball screw to avoid back driving. Locking device is always included if position indicator is selected.

The position indicator has 4 digits where the tree black-background digits represent position in millimetre and the red-backgrounds digit 1/10 of a millimetre.

Customized machining of the drive- and mounting interfaces, higher level of corrosion resistance or low/high temperature versions, please contact Rollco.

Note that “stroke” for a R+L unit refers to the stroke of each individual slider.

Bellow for Linear Unit QME is recommended for all applications where the unit isn't protected against dust and dirt. The bellow may also work as a pinch protection.

All dimensions in mm.

QME12-2xstroke: Max. L tot: 1 000 mm

QME20-2xstroke: Max. L tot: 1 500 mm

QME30-2xstroke: Max. L tot: 2 000 mm

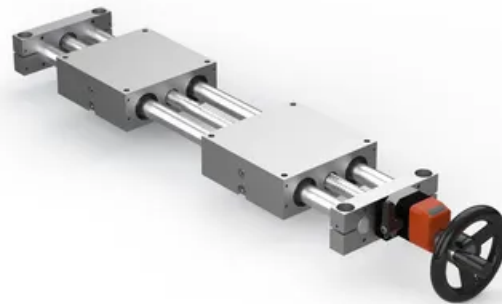

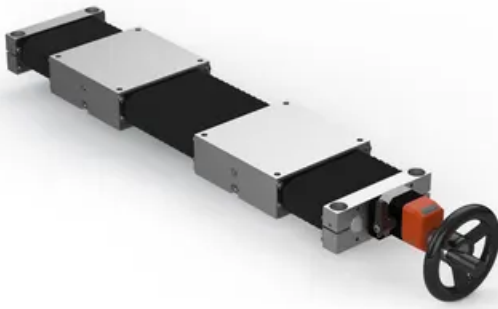

General Data

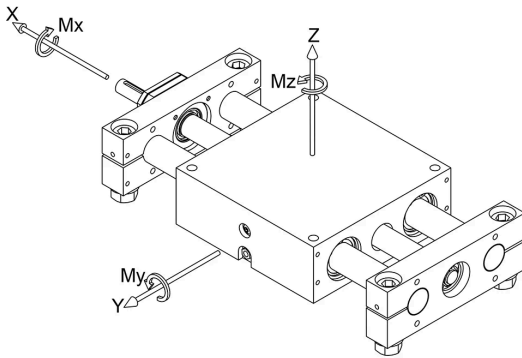

Permissible load Fz and Fy

Permissible load based on a shaft deflection of 1/1000 of Ltot. For long units, actual load may need to be reduced to achieve a deflection acceptable for the application. Please note that the graph below refers to an entire unit and not per slider.

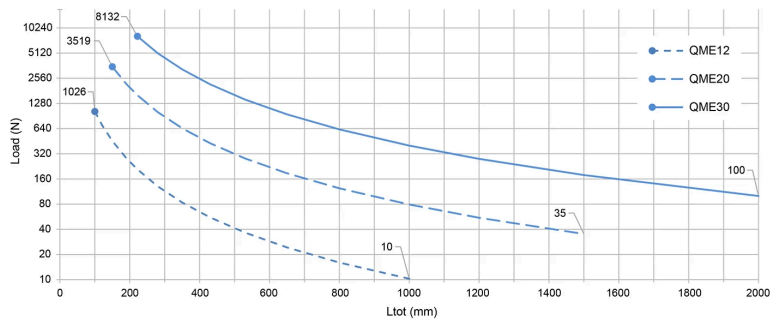

All capacity values are based on the individual ratings of the linear ball bearings used inside the QME and are without any safety factor. The usable load level depends on required service life and the system configuration. The safety factor depends on the application and its requested safety. We recommend a minimum dynamic safety factor 5.

Note! The values in the table below for a Right+Left Unit are given per slider.

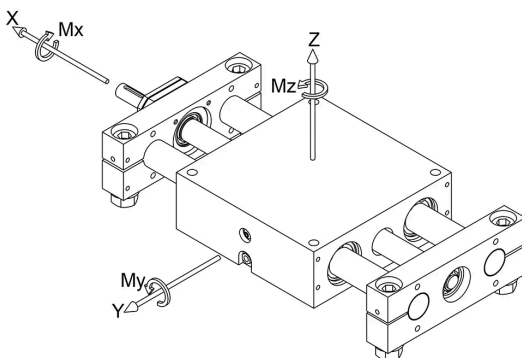

Permissible load Fx

Permissible load is based on the buckling limit of the drive screw. For QME30, buckling will never occur due to the use of oversized drive screws.

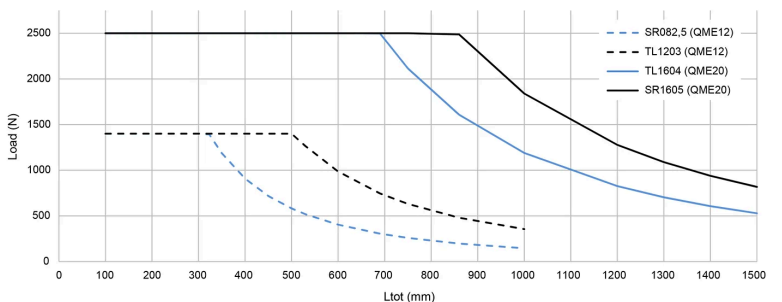

All capacity values are based on the individual ratings of the linear ball bearings used inside the QME and are without any safety factor. The usable load level depends on required service life and the system configuration. The safety factor depends on the application and its requested safety. We recommend a minimum dynamic safety factor 5.

Note! The values in the table below for a Right+Left Unit are given per slider.

Designation	Screw Type	Static Load Capacity Fz (N)	Dynamic Load Capacity Fz (N)	Static Load Capacity Fy (N)	Dynamic Load Capacity Fy (N)
QME12-2xStroke-WIL	TR/TL1203	3160	2080	3160	2080
QME20-2xStroke-WIL	TR/TL1604	5600	3520	5600	3520
QME30-2xStroke-WIL	SR/SL3205	11200	6400	11200	6400

Designation	Static Load Capacity Mx (Nm)	Dynamic Load Capacity Mx (Nm)	Static Load Capacity My (Nm)	Dynamic Load Capacity My (Nm)	Static Load Capacity Mz (Nm)	Dynamic Load Capacity Mz (Nm)
QME12-2xStroke-WIL	71	47	74	49	74	49
QME20-2xStroke-WIL	202	127	216	136	216	136
QME30-2xStroke-WIL	728	416	678	387	678	387

Designation	Dynamic Capacity Ca (N)	Permissible Fx (N)
QME12-2xStroke-WIL	2030 (n/a for TR)	1400
QME20-2xStroke-WIL	7100 (n/a for TR)	2500
QME30-2xStroke-WIL	9500 (n/a for TR)	3200

Dimensions

QME12-2xStroke-WIL

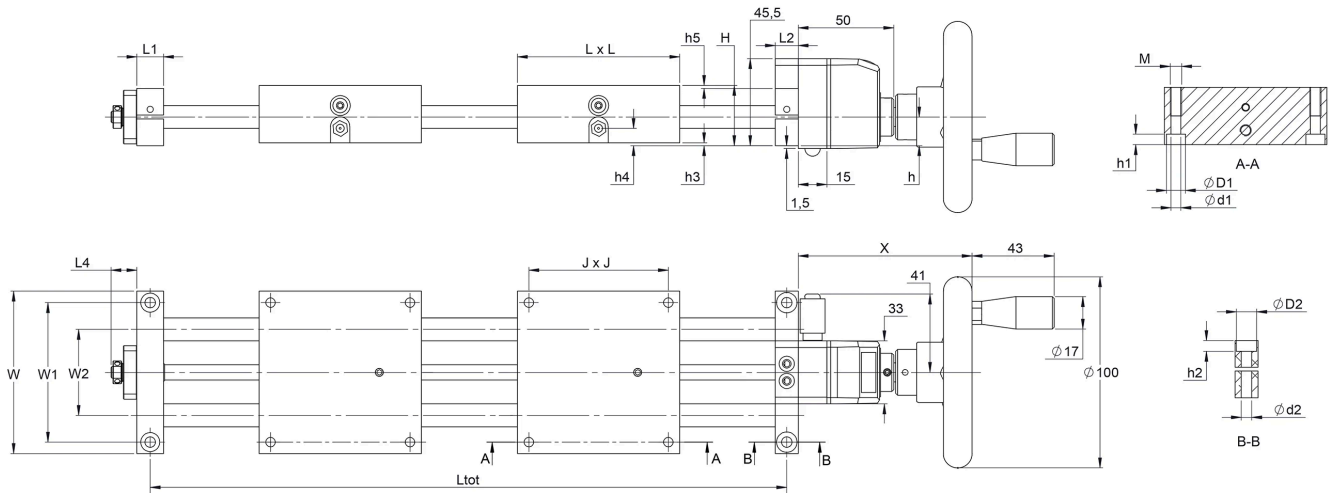

QME20-2xStroke-WIL

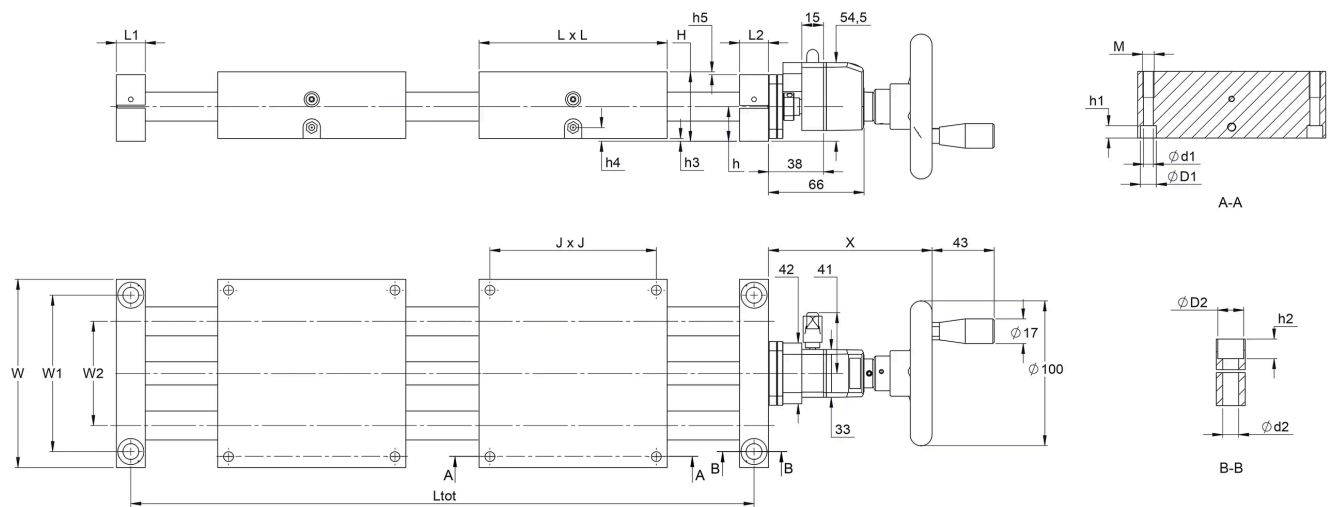

QME30-2xStroke-WIL

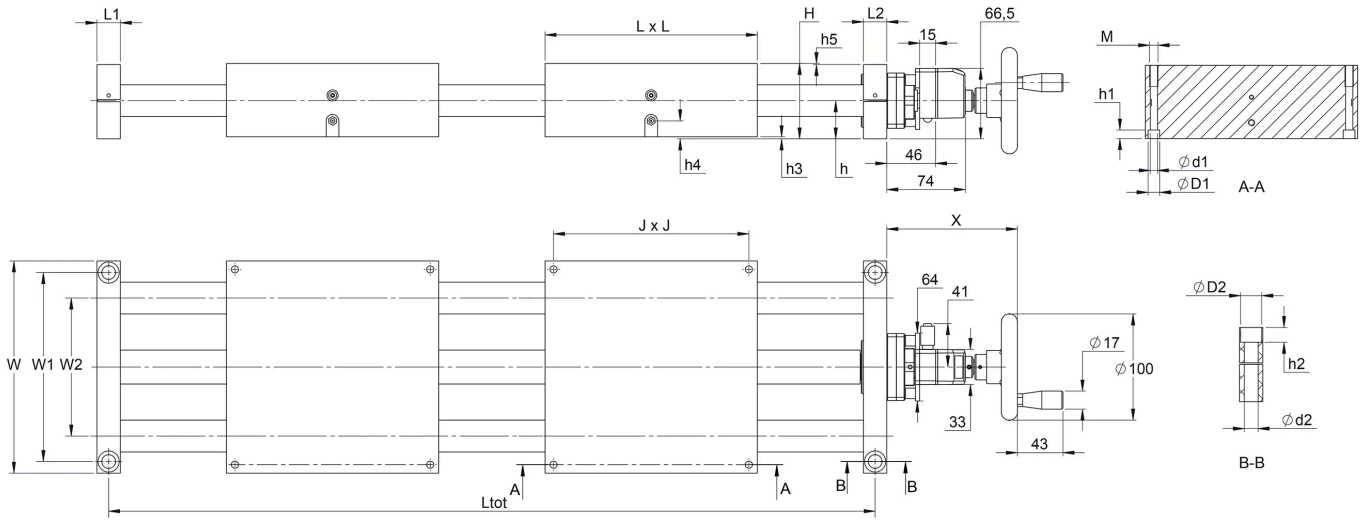

Stroke definition right/left

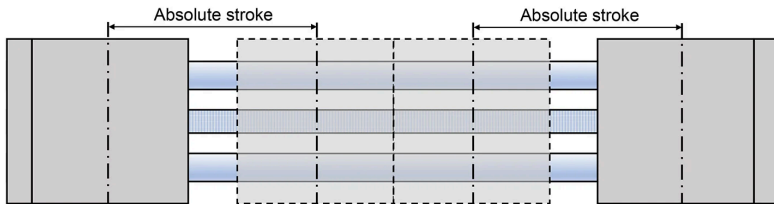

Working stroke: Is the working stroke of the application.
 Absolute stroke: Is defined as Working stroke + Stroke reserve.
 Stroke reserve: Is a safety distance to the mechanical end positions.

	Max. Ltot	Max. absolute stroke	
		no bellow	with bellow
QME12-2xStroke	1 000 mm	409 mm	310 mm
QME20-2xStroke	1 500 mm	610 mm	486 mm
QME30-2xStroke	2 000 mm	789 mm	659 mm

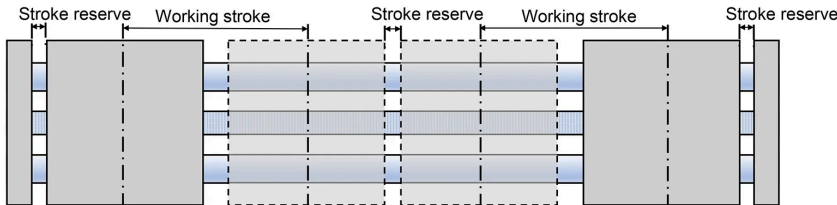

Designation	Ltot	Bellow Ltot	D1	d1	D2	d2	H	h	h1
QME12-2xStroke-WIL	Absolute stroke *2+183	Absolute stroke *2.56+206	10	5.2	10	5.5	31.5	15	5.5
QME20-2xStroke-WIL	Absolute stroke *2+280	Absolute stroke *2.46+303	11	6.8	18	11	48	24	8
QME30-2xStroke-WIL	Absolute stroke *2+422	Absolute stroke *2.36+445	11	6.8	20	13	71	36	8

Designation	h2	h3	h4	h5	J	L	L1	L2	L4	M
QME12-2xStroke-WIL	5.7	1.5	7.5	1.5	73	85	12	14	13.5	M6 x 15
QME20-2xStroke-WIL	13.5	2	7.5	2	115	130	20	20	-	M8 x 18
QME30-2xStroke-WIL	14	2	15	1	184	200	22	22	-	M8 x 20

Designation	W	W1	W2	X
QME12-2xStroke-WIL	85	73	45	91
QME20-2xStroke-WIL	130	108	72	113.5
QME30-2xStroke-WIL	200	178	130	123

Weight

Designation	Zero stroke (kg)	Moving part (kg)	+/100 mm stroke (kg)	Remark
QME12-2xStroke-WIL	1.72 / 1.76 with bellows	0.55 / 0.57 with bellows	0.43 / 0.55 with bellows	Masses may deviate +/- 5% depending on screw type and other options.
QME20-2xStroke-WIL	5.92 / 6.00 with bellows	1.76 / 1.80 with bellows	1.29 / 1.59 with bellows	Masses may deviate +/- 5% depending on screw type and other options.
QME30-2xStroke-WIL	20.2 / 20.5 with bellows	5.77 / 5.91 with bellows	3.46 / 4.08 with bellows	Masses may deviate +/- 5% depending on screw type and other options.