

Linear Unit MTJ 110

The MTJ linear units have toothed belt drive and compact dimensions to provide high performance features such as high speed and good accuracy.

The unit MTJ have a pre-tensioned steel reinforced AT polyurethane timing toothed belt. In conjunction with a zero-backlash drive pulley high moments with alternating loads with good positioning accuracy, low wear and low noise can be realized.

All parts in the profile are protected from dust and other contaminations. As corrosion-resistant protection strip is available as option.

Modulus of Elasticity: $E = 70000 \text{ N / mm}^2$

Operating Temperature (°C): 0 ~ +60 For operating temperature out of the presented range, please contact Rollco.

Duty Cycle: 100%

Max. Acceleration (m/s²): 50 (Optional, acceleration up to 70 m/s² possible if used without INOX seal strip)

Max. Travel Speed (m/s): 1.5 (Optional, travel speed up to 6 m/s possible if used without INOX seal strip)

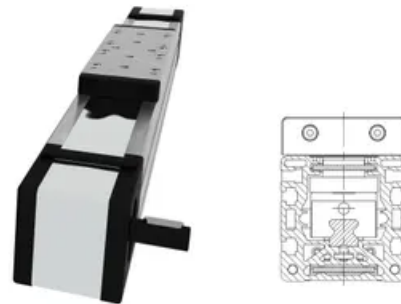

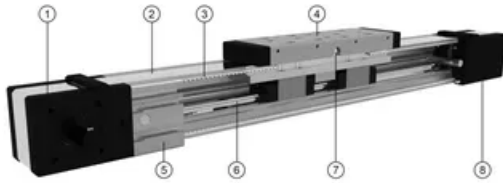

1. Drive block with pulley
2. Corrosion-resistant protection strip (available also without protection strip)
3. AT polyurethane toothed belt with steel tension cords
4. Carriage with built in magnets
5. Aluminium profile-hard anodized
6. Linear ball guideway
7. Central lubrication port, both sides
8. Tension end with integrated belt tensioning system

Deflection of the linear unit

Fixed - fixed mounting

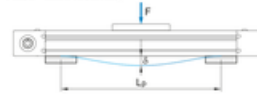

Fixed - free mounting

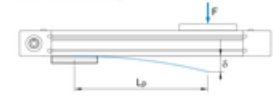

δ Maximum deflection of the linear unit [mm]
 δ_{max} Maximum permissible deflection of the linear unit [mm]
 F Applied force [N]
 L_p Unsupported profile length [mm]

The maximum permissible deflection δ_{max} must not be exceeded. In the case that maximum deflection δ exceeds the maximum permissible deflection δ_{max} additional profile supports are needed.

Deflection of the linear unit

MTJ 110

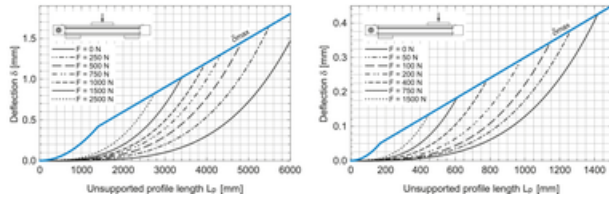

① The linear units do not include any safety stroke.
 Absolute stroke = Effective stroke + 2 x safety stroke.

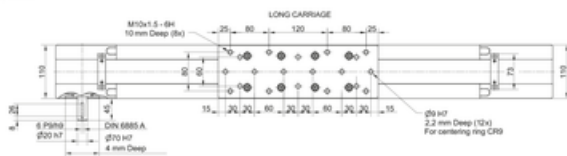

① Journal with or without keyway ② All dimensions in mm. Drawings scales are not equal.

① The linear units do not include any safety stroke.
 Absolute stroke = Effective stroke + 2 x safety stroke.

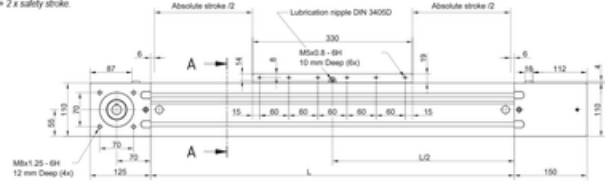

① Journal with or without keyway ② All dimensions in mm. Drawings scales are not equal.

① The linear units do not include any safety stroke.
 Absolute stroke = Effective stroke + 2 x safety stroke.

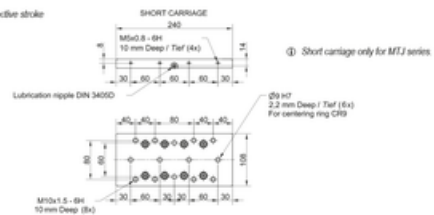

① Journal with or without keyway ② All dimensions in mm. Drawings scales are not equal.

TYPE 0

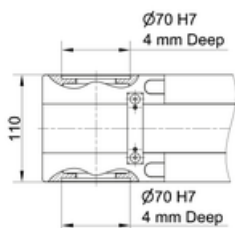
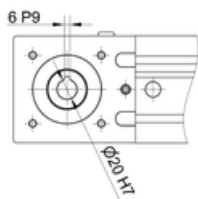

TYPE 1 L and 1 R

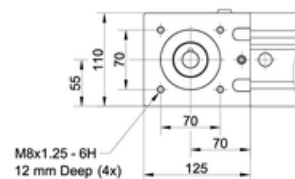

① Journal with or without keyway.

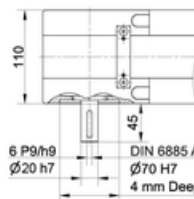

TYPE 2

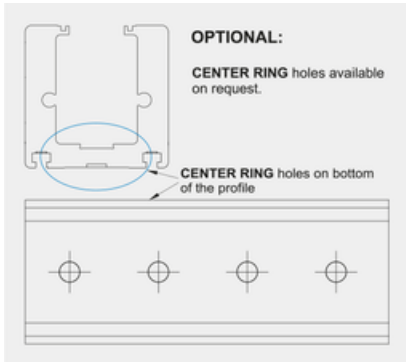
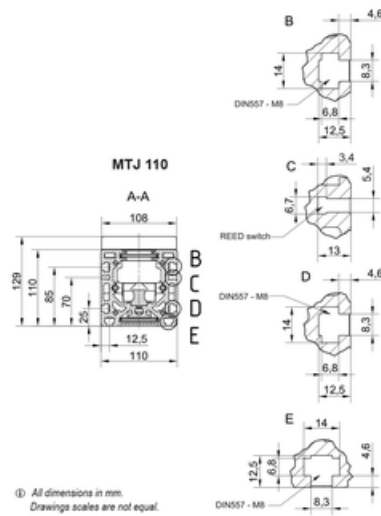
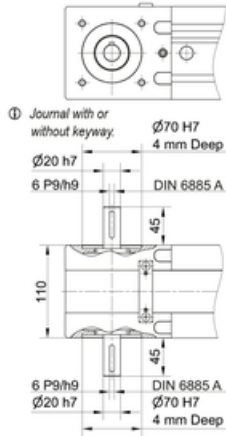

Defining of the linear unit length

$$L = \text{Effective stroke} + 2 \times \text{Safety stroke} + L_v + 12 \text{ mm}$$

$$L_v - \text{Long carriage} = 330 \text{ mm}$$

$$L_{\text{total}} = L + 275 \text{ mm}$$

$$L_v - \text{Short carriage} = 240 \text{ mm}$$

Left side (L)

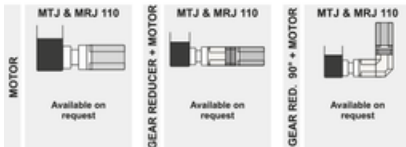
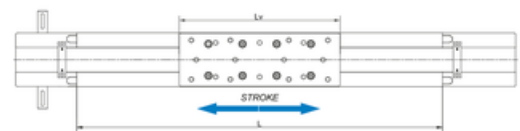

Double Carriage

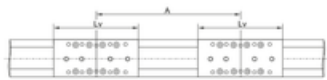

$$L = \text{Effective stroke} + 2 \times \text{Safety stroke} + L_v + A + 12 \text{ mm}$$

$$L_{\text{total}} = L + 275 \text{ mm}$$

$A \geq L_v$

General data

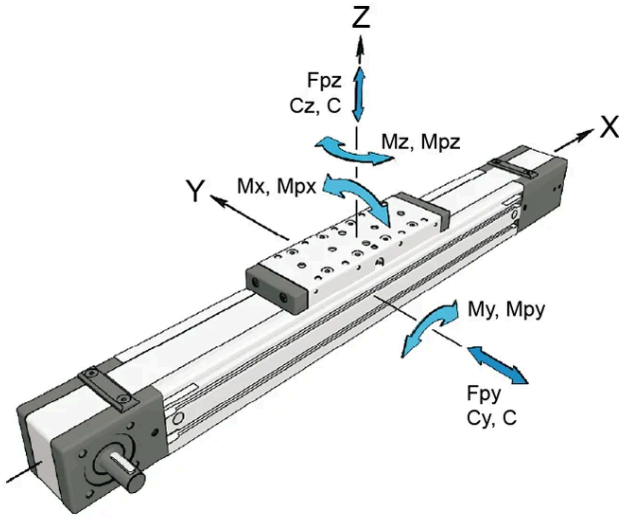

For lengths/stroke over the stated value in the table, please contact Rollco. Values for max. stroke are not valid for double carriage (equation of defining the linear unit length for particular size of the linear unit needs to be used).

For minimum stroke below the stated value in the table, please contact Rollco.

Recommended values of loads

All the data of static and dynamic moments and load capacities stated in the table are theoretical without considering any safety factor. The safety factor depends on the application and its requested safety. We recommend a minimum safety factor ($f_s = 5.0$).

Modulus of elasticity

$E = 70000 \text{ N / mm}^2$

Designation	Carriage Length L_v (mm)	Dynamic Moment M_x (Nm)	Dynamic Moment M_y (Nm)	Dynamic Moment M_z (Nm)	Dynamic Load Capacity C (N)
MTJ 110 S	240	315	220	220	24800
MTJ 110 L	330	630	3840	3840	49600

Designation	Static Load Capacity C_0 (N)	Max. Permissible Loads Forces F_{py} (N)	Max. Permissible Loads Forces F_{pz} (N)	Max. Permissible Loads Moments M_{px} (Nm)	Max. Permissible Loads Moments M_{py} (Nm)	Max. Permissible Loads Moments M_{pz} (Nm)
MTJ 110 S	42500	5000	10130	135	180	100
MTJ 110 L	85000	10000	20260	295	1570	775

Designation	Moved Mass (kg)	Max. Repeatability (mm)	Max. Length L_{max} (mm)	Max. Stroke (mm)	Min. Stroke (mm)
MTJ 110 S	3.25	± 0.08	6000	5748	65
MTJ 110 L	4.61	± 0.08	6000	5658	65

General data double carriage

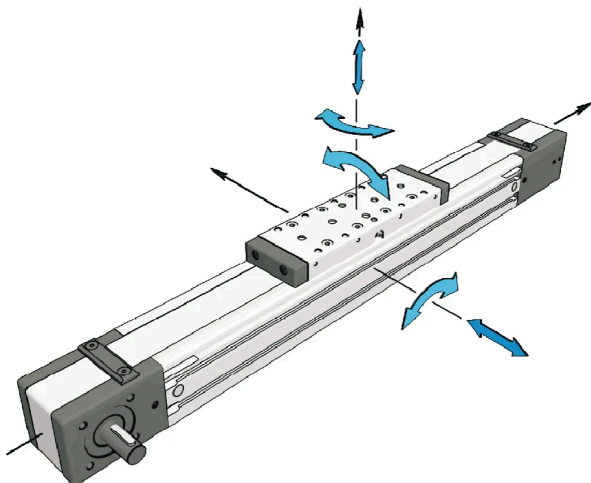

A - Distance between carriages.

Max. travel speed and max. acceleration of linear unit with the corrosion-resistant protection strip is 1,5 m/s and 50 m/s² respectively.

The stated values are for strokes up to 500 mm. No load torque value increases with stroke elongation.

Max. acceleration (m/s²): 70

For acceleration over the stated value, please contact Rollco.

Designation	Carriage version	Dynamic Load Capacity C (N)	Static Load Capacity C0 (N)	Dynamic Moment Mx (Nm)	Dynamic Moment My (Nm)
MTJ 110 S	S2	49600	85000	630	24.8 × A (mm)
MTJ 110 L	L2	99200	170000	1260	49.6 × A (mm)

Designation	Dynamic Moment Mz (Nm)	Max. Permissible Loads Forces Fpy (N)	Max. Permissible Loads Forces Fpz (N)	Max. Permissible Loads Moments Mpx (Nm)	Max. Permissible Loads Moments Mpy (Nm)	Max. Permissible Loads Moments Mpz (Nm)
MTJ 110 S	24.8 × A (mm)	10000	20260	270	10.1 × A (mm)	5.0 × A (mm)
MTJ 110 L	49.6 × A (mm)	20000	40510	590	20.3 × A (mm)	10.0 × A (mm)

Drive data

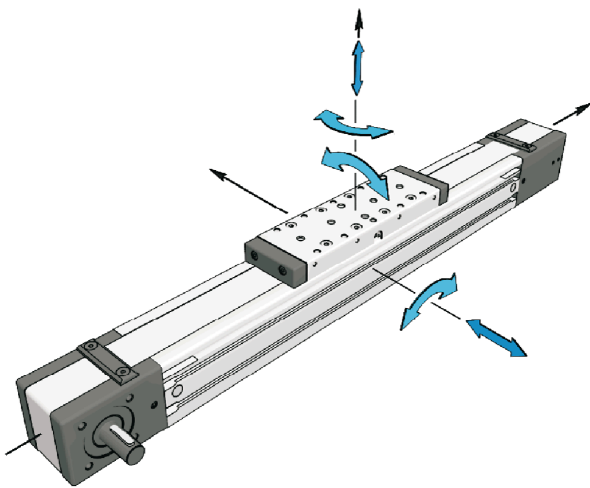

Max. travel speed and max. acceleration of linear unit with the corrosion-resistant protection strip is 1,5 m/s and 50 m/s² respectively.

The stated values are for strokes up to 500 mm. No load torque value increases with stroke elongation.

Max. acceleration (m/s²): 70

For acceleration over the stated value, please contact Rollco.

Mass calculation does not include mass of motor, reduction gear, switches and clamps.

Abs. stroke	Absolute stroke [mm]
A	Distance between carriages [mm]
nc	Number of carriages

Designation	Max. Drive Torque Ma with Keyway (Nm)	Max. Drive Torque Ma without Keyway (Nm)	No Load Torque with Strip (Nm)	No Load Torque without Strip (Nm)	Pulley Drive Ratio (mm/rev)
MTJ 110 S	68.5	82.6	1.8	1.5	300
MTJ 110 L	68.5	82.6	2	1.7	300

Designation	Pulley Diameter	Belt Type	Belt Width	Max. Force Transmitted by Belt (N)	Specific Spring Constant Cspec (N)	Planar Moment of Inertia Iy (cm ⁴)
MTJ 110 S	95.49	AT 10	50	1730	2145000	513
MTJ 110 L	95.49	AT 10	50	1730	2145000	513

Designation	Planar Moment of Inertia Iz (cm ⁴)
MTJ 110 S	620
MTJ 110 L	620

Mass and Mass moment



Max. travel speed and max. acceleration of linear unit with the corrosion-resistant protection strip is 1,5 m/s and 50 m/s² respectively.

The stated values are for strokes up to 500 mm. No load torque value increases with stroke elongation.

Max. acceleration (m/s²): 70

For acceleration over the stated value, please contact Rollco.

Mass calculation does not include mass of motor, reduction gear, switches and clamps.

Abs. stroke	Absolute stroke [mm]
A	Distance between carriages [mm]
nc	Number of carriages

Designation	Mass of Linear Unit (kg)	Mass Moment of Inertia (10 ⁻⁵ kg m ²)	Planar Moment of Inertia I _y (cm ⁴)	Planar Moment of Inertia I _z (cm ⁴)	Moved Mass (kg)
MTJ 110 S	$15.0 + 0.015 \times (\text{Abs. Stroke} + (nc - 1) \times A) + 3.25 \times (nc - 1)$	$1065.0 + 0.137 \times (\text{Abs. Stroke} + (nc - 1) \times A) + 741.9 \times (nc - 1)$	513	620	3.25
MTJ 110 L	$17.7 + 0.015 \times (\text{Abs. Stroke} + (nc - 1) \times A) + 4.61 \times (nc - 1)$	$1381.0 + 0.137 \times (\text{Abs. Stroke} + (nc - 1) \times A) + 1050.9 \times (nc - 1)$	513	620	4.61