

PSD 40 - Shaft 5 mm solid

- Software features: spindle compensation drive, increased breakaway performance, synchronized run
- Software modules for IO-Link: changeover of parameter set, target speed in process data and modulo function
- Protection of internal electronics against manual operation
- Space-saving, compact design
- Galvanically separated supply voltages between control and motor and bus
- Precise position feedback thanks to an absolute measurement system without battery
- Optional gearbox for more torque
- Address may be set using the bus or an address switch (not for IO-Link)
- Status LEDs visible from the outside



Self-holding torque below at approx. 60 mA supply current and 0.5 A phase current, currentless 0 Nm.

Dimensions in mm.

See link Manual(s) for documentation and software.

Type: Horizontal

Nominal Torque (Nm): 0.8

Nominal Speed (rpm): 200

Nominal Voltage (V DC): 24 ($\pm 10\%$)

Nominal Current (A): 2.0

Output Shaft (mm): 5

Output Shaft Type: Solid

Rotation Shaft / Housing: Direct or 0°

BUS Communication: Can Open (CA); IO-Link (IO);

ProfiNet (PN); EtherCat (EC); Ethernet IP (EI)

Electrical connection: 0: Standard

Protection Class: IP50; IP65

Motor: Stepper motor

Supply Voltage: 24 V DC $\pm 10\%$ galvanically separated between motor and control

Measurement System: Absolute without battery

Accuracy: " $\pm 0.7^\circ$ for versions with gearbox; $\pm 1.8^\circ$ for versions without gearbox"

Intermittence: Start-up duration up to 50%

Manual Adjustment: No

Brake: No

Performance Curve - Direct Drives PSD



General Data

PSD 401-5V (solid shaft)

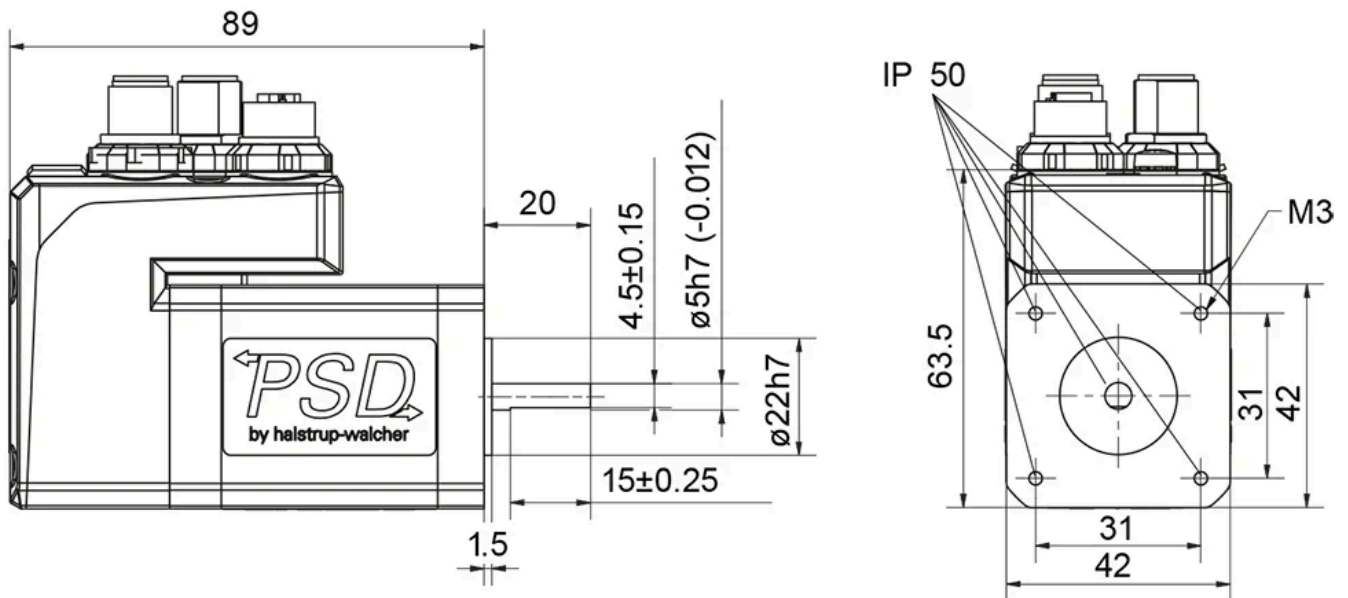

Designation	Nominal Torque (Nm)	Nominal Speed (rpm)	Nominal Current (A)	Self-holding Torque (Nm)	Max. Speed (rpm)
PSD 401-5V	0.8	200	2.0	0.4	800
Designation	Positioning Range (rot.)				
PSD 401-5V	4026				