

PSS 30 - Shaft 14 mm solid

- Positioning system with IP 65
- Absolute measuring system, without battery
- Galvanically separated supply voltages between control and motor and bus
- Absolute encoder eliminates the need for reference runs during system setup and installation of replacements
- Easy address assignment directly on the device using integrated address switches (not for IO-Link)
- Manual disconnecting lever permits manual disconnection of the gearbox
- Regulation of the current torque prevents overloading and unnecessary run aborts
- Strong breakaway torque enables safe start-up even after an extended standstill
- Intelligent running behaviour. Recognises the difference between obstacles and dirt
- Spindle offset run: Excludes inconsistencies due to lash in the spindle
- Condition monitoring of supply voltage, drag error (permits optimum adjustment of current position), power consumption and torque
- Partial safety function for STO (Safe Torque Off)



Dimensions in mm.

Contact us for CAD-files.

Type: Horizontal

Nominal Voltage (V DC): 24 (± 10 %)

Nominal Current (A): 2.4

Output Shaft (mm): 14

Output Shaft Type: Solid

BUS Communication: Can Open (CA); Profi Bus (DP); Device Net (DN); Modbus (MB); IO-Link (IO); ProfiNet (PN); Sercos (SE); EtherCat (EC); Ethernet IP (EI); PowerLink (PL)

Electrical connection: "Standard; with jog keys; 1 connector Y-encoded or 1 connector Y-encoded with jog keys"

Protection Class: IP65

Motor: EC-motor

Supply Voltage: 24 V DC ± 10 % galvanically separated between control and motor and bus

Measurement System: Absolute, optical-magnetic

Accuracy: ± 0.9°

Intermittence: 20% (basis time 600 s)

Manual Adjustment: Standard

Brake: Optional (holding brake)

Material: Stainless steel housing. See pdf for details.

Performance Curve - Direct Drives PSS

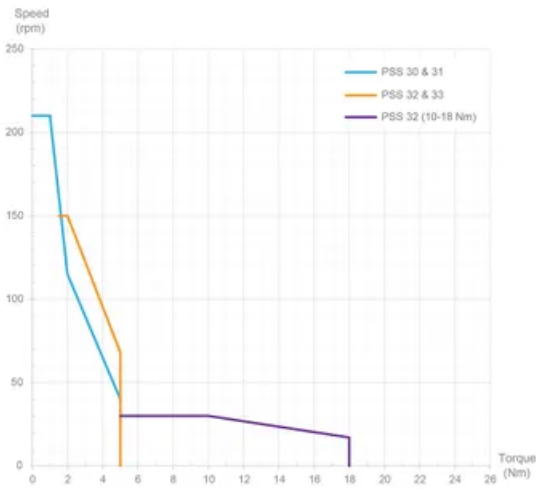

General Data

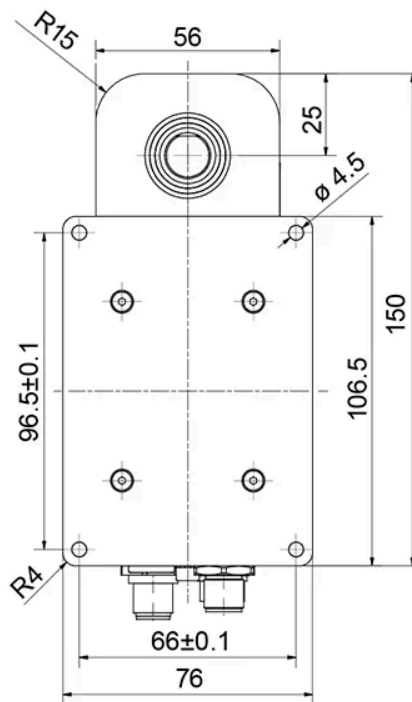
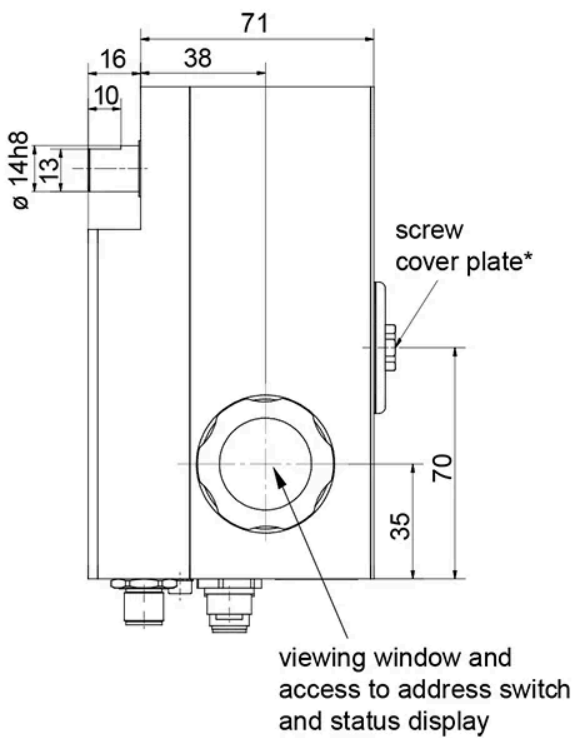

* over a rotating manual adjustment shaft SW 6/8 depth hex

Designation	Nominal Torque (Nm)	Nominal Speed (rpm)	Nominal Current (A)	Self-holding Torque (Nm)	Positioning Range (rot.)
PSS 301-14V	1	210	2.4	0.5	250
PSS 302-14V	2	100	2.4	1	250
PSS 305-14V	5	40	2.4	2.5	250