

PSW 31 - Shaft 8 mm solid

- Positioning system with IP 68
- Absolute measuring system, without battery
- Galvanically separated supply voltages between control and motor and bus
- Absolute encoder eliminates the need for reference runs during system setup and installation of replacements
- Easy address assignment directly on the device using integrated address switches (not for IO-Link)
- Manual disconnecting lever permits manual disconnection of the gearbox
- Regulation of the current torque prevents overloading and unnecessary run aborts
- Strong breakaway torque enables safe start-up even after an extended standstill
- Intelligent running behaviour. Recognises the difference between obstacles and dirt
- Spindle offset run: Excludes inconsistencies due to lash in the spindle
- Condition monitoring of supply voltage, drag error (permits optimum adjustment of current position), power consumption and torque
- Partial safety function for STO (Safe Torque Off)



Dimensions in mm.

Type: Vertical

Nominal Voltage (V DC): 24 ($\pm 10\%$)

Nominal Current (A): 2.2

Output Shaft (mm): 8

Output Shaft Type: Solid

BUS Communication: Can Open (CA); Profi Bus (DP); Device Net (DN); Modbus (MB); IO-Link (IO); ProfiNet (PN); Sercos (SE); EtherCat (EC); Ethernet IP (EI); PowerLink (PL)

Electrical connection: "Standard; with jog keys; 1 connector Y-encoded or 1 connector Y-encoded with jog keys"

Protection Class: IP68

Motor: EC-motor

Supply Voltage: 24 V DC $\pm 10\%$ galvanically separated between control and motor and bus

Measurement System: Absolute, optical-magnetic

Accuracy: $\pm 0.9^\circ$

Intermittence: 20% (basis time 600 s)

Manual Adjustment: No

Brake: No

Material: All components in stainless steel. (Except for feather key, if available.)

Performance Curve - Direct Drives PSW



General Data

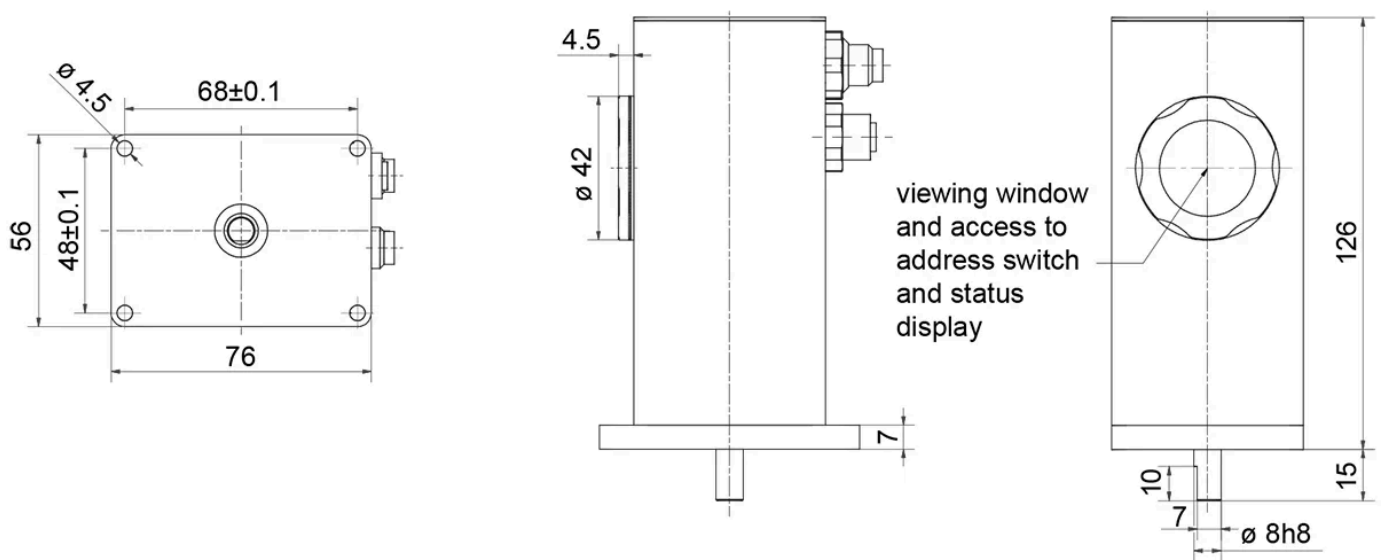

| Designation | Nominal Torque (Nm) | Nominal Speed (rpm) | Nominal Current (A) | Self-holding Torque (Nm) | Positioning Range (rot.) |
|-------------|---------------------|---------------------|---------------------|--------------------------|--------------------------|
| PSW 311-8V | 1 | 180 | 2.2 | 0.5 | 250 |
| PSW 312-8V | 2 | 100 | 2.2 | 1 | 250 |
| PSW 315-8V | 5 | 35 | 2.2 | 2.5 | 250 |